

REGULATOR RÓŻNICY CIŚNIEŃ RRC-4

FUNCTION

Pressure regulators are designed to maintain set-up, constant pressure difference in process installations, which are connected in series to regulator's valve outlet. Regulators are adjusted to steam, liquids and inflammable gases.

CONSTRUCTION

Regulator comprises three main units:

- double-seated valve (1),
- actuator (2)
- adjuster set (3).

Diaphragm actuator can have the following effective diaphragm area: 100 cm², 160 cm², 320 cm², depending on the pressure difference required. Actuator is connected to the valve through adjuster set (which consists of a spring /s/ with spring spacers). Valve's and actuator's stems are sealed by means of elastic bellows made from stainless steel. The bellows do not require service during operation. Regulator's valve is closed on power failure.

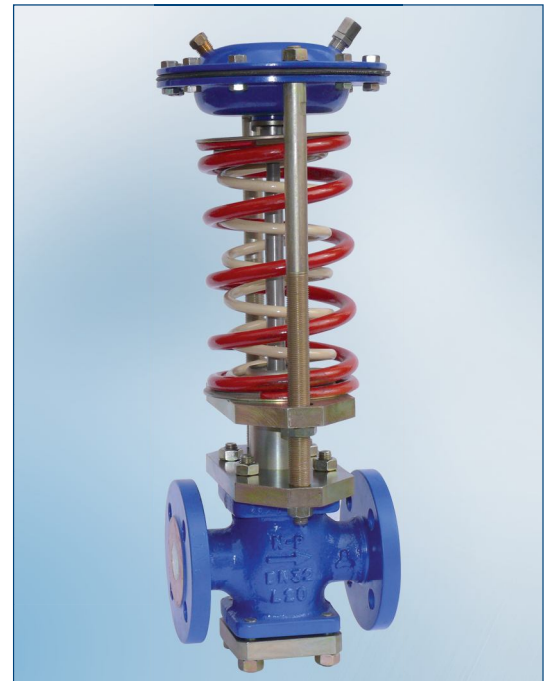

PRINCIPLE OF OPERATION

Regulator RRC-4:

- higher pressure impulse (P”+“) is applied to actuator chamber through adjuster set;
- lower pressure impulse (P”-“) is applied to actuator outer chamber.

The spring tension should be such as to allow for equilibrium of forces, when pressure difference achieves its set-up value. If the set-up value is exceeded, equilibrium of forces gets disturb, which causes valve plug to open and flow rate through the valve to increase till the regulated pressure drops down to its set-up value.

NOTE:

1. In order to avoid excess noise, it is recommended to maintain $p_r (abs) > \frac{1}{2} p_{zas} (abs)$.
2. Kvs values of regulators are selected by the manufacturer according to individual needs of Customer.
3. Please advise regulated pressure of the regulator while ordering, and the regulator will be set accordingly.

Pressure		
Nominal pressure	valve	PN40
	flanges	PN16/40
Max. fluid pressure		2,5 MPa
Proportionality range		Xp=16%

Medium	Max. fluid temp	Leakage class
air, gases	90°C	VI kl. wg. PN-EN 60534-4
water, steam	240°C	VI kl. wg. PN-EN 60534-4
	300°C DN15-50 „metal-metal”	IV kl. wg. PN-EN 60534-4

MATERIALS

	MATERIALS		Norm
Body	GP240GH	1.0619	PN-EN 10213-2
	GX5CrNiMo19-11-2	1.4408	PN-EN 10213-4
Bonnet	C15E	1.1141	EN 10084
	X6CrNiTi18-10	1.4541	PN EN 10088
Plug, Seat	X17CrNi16-2	1.4057	
	X6CrNiTi18-10	1.4541	
Elastic Bellow	X6CrNiMoTi17-12-2	1.4571	
Plug sealing	PTFE+ brąz lub grafit		
	EPDM		
	NBR		
Diaphragm	EPDM z tkaniną poliestrową		
	NBR z tkaniną poliestrową		

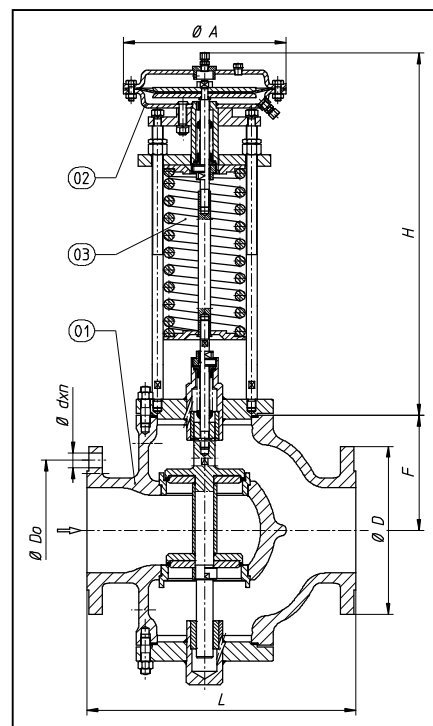

DIMENSIONS

Regulator's Size DN		65	80	100	150	200	
Max. coefficient Kvs ¹⁾		95	120	150	320	400	
Dimensions [mm]	D [mm]	PN16	185	200	220	285	340
		PN25-40			235	300	375
	L [mm]	PN 16-40	290	310	350	480	600
	D ₀ [mm]	PN16	145	160	180	240	295
		PN25-40			190	250	320
	d [mm]	PN16	18	18	18	22	22
		PN25-40			22	26	30
	n	PN16	4	8	8	8	12
	PN25-40	8					
F [mm]		111	133,5	149	205	250	
Regulator's weight [kg]		49	58	75	157	220	

1) Other Kvs coefficients available on request

SETTING RANGES OF REGULATED PRESSURE²⁾

Actuator		Setting ranges [kPa]					
Area [cm ²]	Ø A						
160	230	30-160	50-240	60-300	80-400	100-480	100-560
320	290		10-40	15-80	30-160	50-280	80-375 100-550
Max. height	H				400		625

2) Other setting ranges available on request

INSTALLATION

Regulator should be mounted on a horizontal pipeline with the spring facing downward. Direction of fluid flow must be as indicated on the regulator's valve body. It is recommended to install strainer type FS in front of the regulator. Regulators are equipped with impulse pipe connections, which are already fastened, and impulse pipes to be fastened. Additionally, steam regulators are equipped with condensers and connection stubs for the pipeline. Regulator is set at the regulated pressure required when supplied